

NORDICMED

SCANDINAVIAN HEALTHCARE PROFESSIONALS

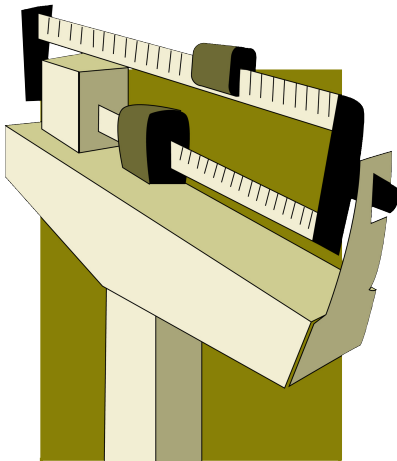

F.A.Q.

Q: Who will assist me in getting my Green Card?

NordicMed will sponsor you as well as pay for your INS application fee.

Q: Will my family be able to come over to the U.S.?

Most certainly. Once you obtain your Green Card through NordicMed your family may join you in the U.S. NordicMed encourages you to bring family with you. We believe that by having your family close to you it will make your experience working in the United States more enjoyable.

Q: What salary can I expect to make?

Your salary will depend upon your level of experience and field of nursing. Typically, salaries are twice those that are earned by nurses in Scandinavia. NordicMed will offer to cover a large portion of your living expenses (e.g., rent, insurance, utilities, etc) and insurance while working for NordicMed. Lastly, you will receive a bonus for every 6 months you have worked for NordicMed.

Q: What benefits will I be eligible for?

NordicMed offers a competitive benefits package that follows the industry standards, and more. Please refer to the benefits sheet included in this folder.

Q: Will I be reimbursed for any of the examinations?

NordicMed will reimburse you for all the required exams.

Q: What will I do for health insurance coverage? Will my family be covered as well?

NordicMed will pay for your health insurance (You may have to pay a small fee for any additional family member's coverage).

Q: How will I find housing?

NordicMed will provide and pay housing for you.

Q: Will I be eligible for bonuses?

Yes, after completing each contract you will receive a bonus. The amount of the bonus depends upon the location, length of contract and position.

Q: What is the length of a contract with NordicMed?

Employment terms begin from 18 months to as long as you desire to work with NordicMed. We will strive to gain your trust and confidence in our services. Once you have completed your contract you may continue to work for NordicMed.

Q: What is the typical length of a contract at a Hospital in the U.S.?

Contracts range anywhere from 6 months to 2 years. Depending upon your performance the hospital may wish to renegotiate your contract (for a higher salary) when it comes to term. You may or may not renew the contract at that time.

NORDICMED USA

P.O. Box 1222
Andover, MA 01810 USA
info@NordicMed.com
www.NordicMed.com
1 (877) -966-7342
1 (877) -9NORDIC

F.A.Q.

NordicMed Massachusetts
P.O. Box 1222
Andover, MA 01810 USA
Phone: 877 - 9NORDIC
Phone: 877 - 966-7342

NordicMed Sweden
Karl Gerhardsväg 25
133 35 Saltsjöbaden, Sweden
Phone: 46 - (08) - 660 62 86
Fax: 46 - (08) - 13 27 10

NordicMed Florida
2940 North Course Dr. #502
Pompano Beach, FL 33069 USA
Phone: 866 - NORMED
Phone: 866-667-3633

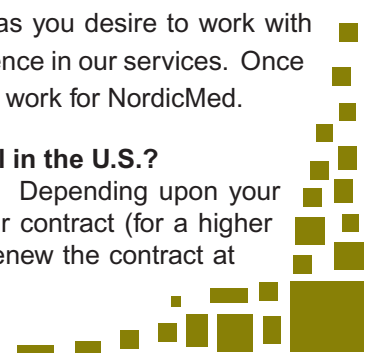

NORDICMED

SCANDINAVIAN HEALTHCARE PROFESSIONALS

Q: Will I be able to take classes or continuing education programs while working in the United States?

NordicMed encourages you to take classes and continuing education courses and will pay for such courses relating to their field of work and contract length.

Q: What if I decide to return to NordicMed but for a shorter period of time?

Once you have completed your contract with NordicMed you can sign a 6 month contract with us. This is a great way for our nurses to spend their winters in Sunny Florida while earning a generous salary. You may even return to Scandinavia and work for NordicMed at a later time.

Q: How does nursing in the U.S. differ from my responsibilities as a nurse in my native country?

As a nurse practicing in Scandinavia you hold more personal and professional responsibility for patient care than do nurses in the United States. For legal reasons, nurses in the United States are required to follow the directives of the attending physician, thus taking much of the burden off of the nurse (and liability, should a patient's condition decline). NordicMed will pay for your liability insurance to give you peace of mind so you can focus on the practice of nursing rather than worry about potential legal problems. If you are concerned about the use of medical equipment and your lack of experience, the hospitals will demonstrate their usage to you during your orientation period, which takes place in the first weeks of your work period.

Q: Where do I get information to sign up for the tests?

1. For information regarding the TOEFL:

Educational Testing Service
P.O. Box 6151
Princeton, NJ 08541-6151 USA
Telephone: (609) 771-7100
Web: <http://www.toefl.org>
Email: toefl@ets.org

2. For information regarding the CGFNS, see their website:

<http://www.cgfns.org/cgfns/index.html>

■ For further information about the requirements, or to receive the CGFNS handbook and application form, visit NordicMed's website regarding requirements at:

<http://www.nordicmed.com/requirement.html>

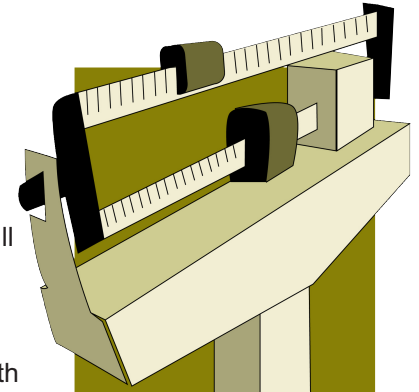

NORDICMED USA

P.O. Box 1222
Andover, MA 01810 USA
info@NordicMed.com
www.NordicMed.com
1 (877) -966-7342
1 (877) -9NORDIC

F.A.Q.

NordicMed Massachusetts
P.O. Box 1222
Andover, MA 01810 USA
Phone: 877 - 9NORDIC
Phone: 877 - 966-7342

NordicMed Sweden
Karl Gerhardsväg 25
133 35 Saltsjöbaden, Sweden
Phone: 46 - (08) - 660 62 86
Fax: 46 - (08) - 13 27 10

NordicMed Florida
2940 North Course Dr. #502
Pompano Beach, FL 33069 USA
Phone: 866 - NORDMED
Phone: 866-667-3633

